

# Monark 23:1; President 30:1 and 46:1

## Airless Spray Packages

### Features and Benefits

- Airless spray technology allows ability to spray a variety of fluids from conventional coatings to high performance corrosion control coatings
- Extremely reliable and proven Monark and President pumps
- Ergonomic and easy-to-use packages for the operator
- Features Silver Plus airless gun

### Typical Applications

- Rail
- Tanks
- Marine
- Corrosion control
- Farm and construction
- General metal fabrication

### Typical Fluids Handled

- Epoxies
- Polyurethanes
- Alkyds
- Enamels
- Waterborne

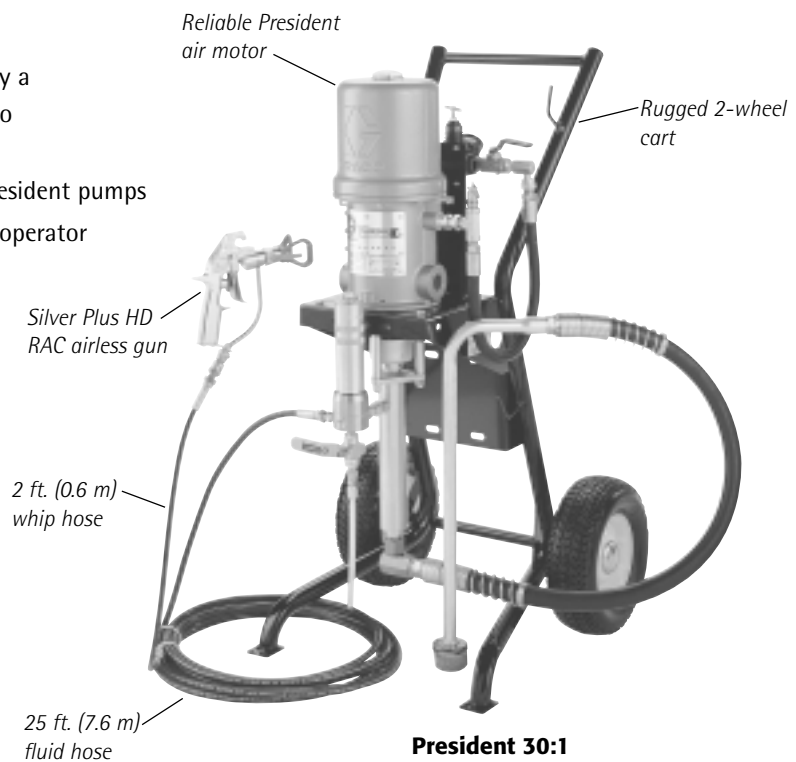

**President 30:1  
Heavy-Duty Cart Package  
231921**

# Monark 23:1; President 30:1 and 46:1 Airless Spray Packages

## Technical Specifications

	<b>Monark 23:1</b>	<b>President 30:1</b>	<b>President 46:1</b>
Pump ratio			
Maximum fluid outlet pressure	2300 psi (160 bar, 16.0 MPa)	3000 psi (210 bar, 21.0 MPa)	4600 psi (317 bar, 31.7 MPa)
Maximum air input pressure	100 psi (7 bar, 0.7 MPa)	100 psi (7 bar, 0.7 MPa)	100 psi (7 bar, 0.7 MPa)
Fluid Flow @ 60 cpm	0.4 gpm (1.6 lpm)	1.0 gpm (3.8 lpm)	0.5 gpm (1.9 lpm)
Volume per cycle	0.9 oz. (27 cc)	2 oz. (62 cc)	1.1 oz. (32 cc)
Pump air consumption at 100 psi (7 bar, 0.7 MPa) air @ 20 cpm	3 scfm (0.08 m <sup>3</sup> /min.)	10 scfm (0.28 m <sup>3</sup> /min.)	10 scfm (0.28 m <sup>3</sup> /min.)
Sound pressure level @ 100 psi (7 bar, 0.7 MPa) air @ 20 cpm	75 dBA	81 dBA	81 dBA
Air inlet, package	3/8 npsm(f)	3/8 npsm(f)	3/8 npsm(f)
Fluid inlet, pump	3/4 npt(m)	3/4 npt(m)	3/4 npt(m)
Fluid outlet, package	1/4 npsm(m)	1/4 npsm(m)	1/4 npsm(m)
Weight			
Wall-mount package	65 lb. (30 kg)	75 lb. (34 kg)	75 lb. (34 kg)
Pail-mount	47 lb. (21 kg)	N/A	N/A
55 gallon (200 l) drum package	N/A	240 lb. (109 kg)	N/A
Light-duty cart	45 lb. (20 kg)	N/A	N/A
Heavy-duty cart	85 lb. (39 kg)	85 lb. (39 kg)	85 lb. (39 kg)

Note: For instruction manual numbers, refer to ordering information

# Monark 23:1; President 30:1 and 46:1 Airless Spray Packages

## Performance Chart for Monark 23:1 Pump

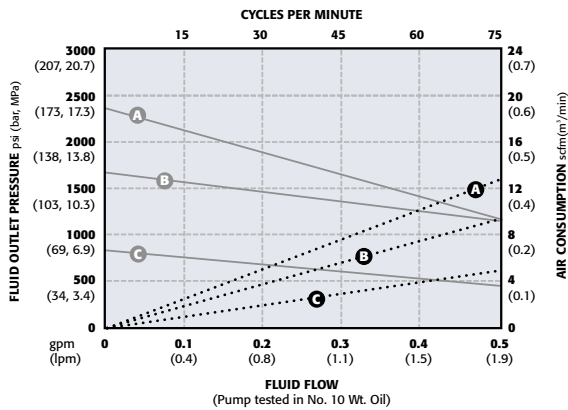

AIR PRESSURES	LEGEND
(A) = @ 100 psi (7 bar, 0.7 MPa)	Air Consumption.....
(B) = @ 70 psi (4.8 bar, 0.5 MPa)	Fluid Flow _____
(C) = @ 40 psi (2.8 bar, 0.3 MPa)	

## Performance Chart for President 30:1 Pump

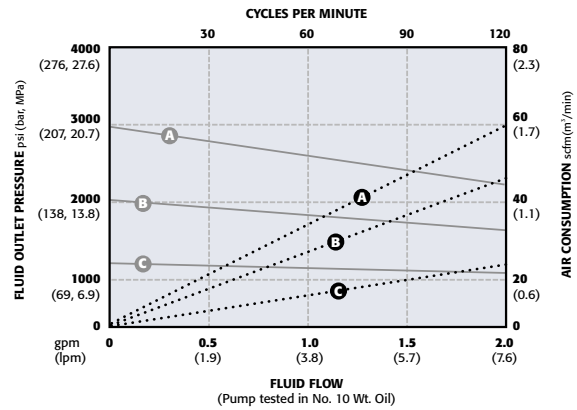

AIR PRESSURES	LEGEND
(A) = @ 100 psi (7.0 bar, 0.7 MPa)	Air Consumption.....
(B) = @ 70 psi (4.8 bar, 0.5 MPa)	Fluid Flow _____
(C) = @ 40 psi (2.8 bar, 0.3 MPa)	

5

## Performance Chart for President 46:1 Pump

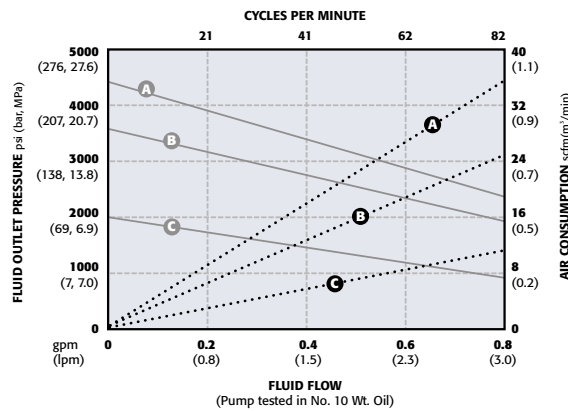

AIR PRESSURES	LEGEND
(A) = @ 100 psi (7.0 bar, 0.7 MPa)	Air Consumption.....
(B) = @ 70 psi (4.8 bar, 0.5 MPa)	Fluid Flow _____
(C) = @ 40 psi (2.8 bar, 0.3 MPa)	

# Monark 23:1; President 30:1 and 46:1 Airless Spray Packages

## Dimensions

### Heavy-Duty Cart-Mount Package

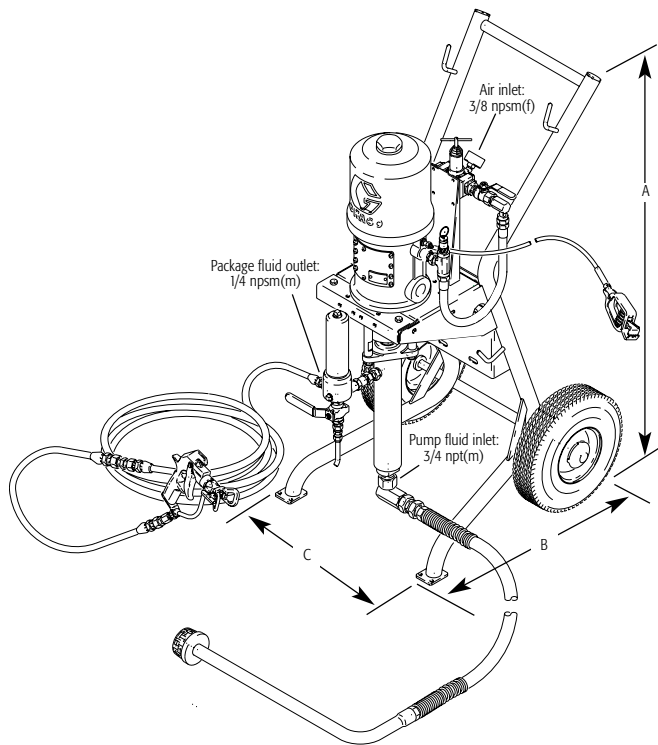

### Monark Pail-Mounted Package

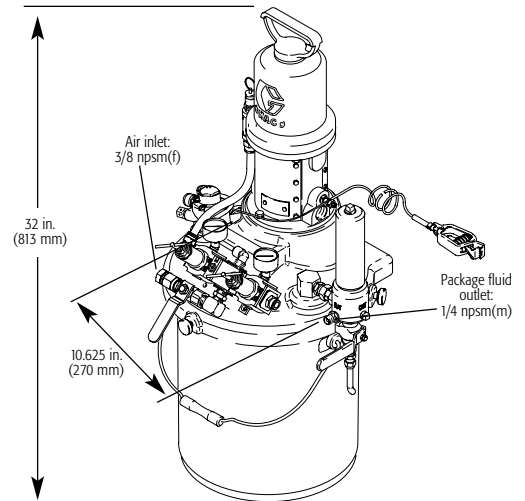

## Dimensions For Heavy-Duty Cart Packages

	A Height	B Depth	C Width
Monark	38.5 in. (978 mm)	21 in. (534 mm)	20 in. (508 mm)
President	38.5 in. (978 mm)	21 in. (534 mm)	20 in. (508 mm)

5

# Monark 23:1; President 30:1 and 46:1 Airless Spray Packages

## Dimensions

### Wall-Mount Package

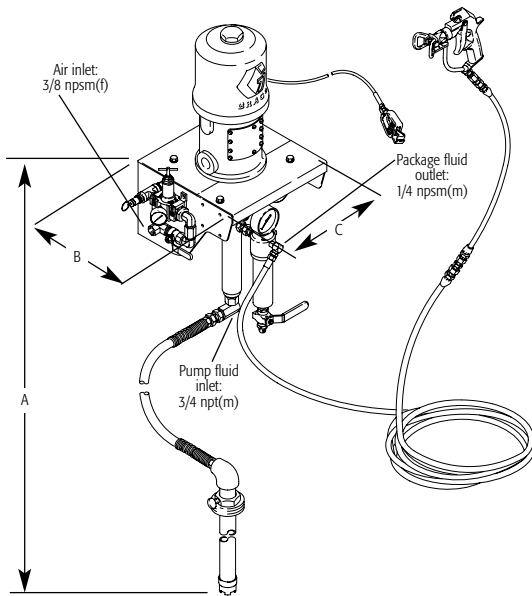

### Light-Duty, Cart-Mount Package

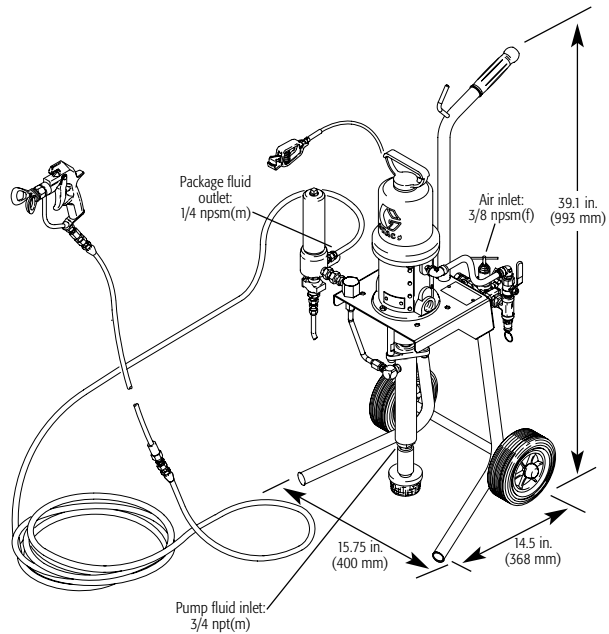

5

## Dimensions For Wall-Mount Packages

	A Height	B Depth	C Width
Monark	Max. 5 ft. (1.8 m)	12 in. (305 mm)	12 in. (305 mm)
President	Max. 5 ft. (1.8 m)	12 in. (305 mm)	12 in. (305 mm)

# Monark 23:1; President 30:1 and 46:1 Airless Spray Packages

## Ordering Information

1. Select appropriate spray package (Monark 23:1, President 30:1 or President 46:1) based on pressure and flow requirements of the application. Refer to Monark and President pump performance charts.
2. Select wall-mount, pail-mount, light-duty cart, heavy-duty cart or 55 gallon (200 l) drum (President 30:1 package only) mounting configuration.
3. Select package construction (carbon steel or stainless steel) based on the corrosive and chemical characteristics of the fluid to be handled.
4. Select package with Silver Plus airless gun or bare (without gun or hoses).
5. Select non-heated or heated package, based on temperature requirements of the fluid to be sprayed.
6. If a heated package is selected, choose 120V, 200V, 240V or 480V voltage, based on electrical installation requirements.
7. For pail-mount configurations, select package with agitator or without agitator.
8. Order package part number.

### MONARK 23:1 AIRLESS SPRAY PACKAGES

2300 psi (160 bar, 16.0 MPa)

Carbon Steel	Stainless Steel	Part Number	Wall-Mount	Pail-Mount	Light-Duty Cart-Mount	Heavy-Duty Cart-Mount	Heated Package	Heater Voltage	Fluid Filter	Agitator	Siphon Tube	Back Pressure Regulator	Circulation Kit	Circulation Manifold	Bare Package - no hose or gun	Fluid Swivel at Gun Inlet	Whip Hose 2 ft. (0.6 m)	Fluid Hose 25 ft. (7.6 m)	Applicator	Instruction Manual
•		232223	•						•	•				•						308756
	•	232234	•						•	•				•						308756
•		232222	•						•	•					•	•	•		Silver Plus Fine Finish	308756
	•	232233	•						•	•					•	•	•		Silver Plus Fine Finish	308756
•		232293	•				•	200	•	•	•	•	•		•	•	•		Silver Plus Fine Finish	308759
	•	232381	•				•	200	•	•	•	•	•		•	•	•		Silver Plus Fine Finish	308759
•		232291	•				•	240	•	•	•	•	•		•	•	•		Silver Plus Fine Finish	308759
	•	232379	•				•	240	•	•	•	•	•		•	•	•		Silver Plus Fine Finish	308759
•		232292	•				•	480	•	•	•	•	•		•	•	•		Silver Plus Fine Finish	308759
	•	232380	•				•	480	•	•	•	•	•		•	•	•		Silver Plus Fine Finish	308759
•		232434		•					•					•						308765
	•	232446		•					•					•						308765
•		232433		•					•						•	•	•		Silver Plus Fine Finish	308765
	•	232445		•					•						•	•	•		Silver Plus Fine Finish	308765
•		232437		•					•	•					•	•	•		Silver Plus Fine Finish	308765
	•	232449		•					•	•					•	•	•		Silver Plus Fine Finish	308765
•		232412		•					•					•						308762
•		232411		•					•						•	•	•		Silver Plus Fine Finish	308762
•		231941			•				•					•						308635
	•	231940			•				•	•					•	•	•		Silver Plus Fine Finish	308635
	•	231949			•				•	•					•	•	•		Silver Plus Fine Finish	308635
•		231942			•				•	•					•	•	50 ft.		Silver Plus Fine Finish	308635
•		231989			•	•	120	•	•	•	•	•	•		•	•	•		Silver Plus Fine Finish	308692
	•	232044			•	•	120	•	•	•	•	•	•		•	•	•		Silver Plus Fine Finish	308692
•		231990			•	•	240	•	•	•	•	•	•		•	•	•		Silver Plus Fine Finish	308692
	•	232045			•	•	240	•	•	•	•	•	•		•	•	•		Silver Plus Fine Finish	308692

Note: Monark 23:1 packages include a 163xxx tip of choice.

# Monark 23:1; President 30:1 and 46:1 Airless Spray Packages

## Ordering Information, continued

### PRESIDENT 30:1 AIRLESS SPRAY PACKAGES

3000 psi (210 bar, 21.0 MPa)

Carbon Steel	Stainless Steel	Part Number	Wall-Mount	55 Gallon (200 l) Drum Mount Elevator	Heavy-Duty Cart-Mount Heated Package	Heater Voltage	Fluid Filter	Agitator	Siphon Tube	Back Pressure Regulator	Circulation Kit	Circulation Manifold	Bare Package - no hose or gun	Fluid Swivel at Gun Inlet	Whip Hose 2 ft. (0.6 m)	Fluid Hose 25 ft. (7.6 m)	Applicator	Instruction Manual
•		232201	•				•		•				•					308756
	•	232212	•				•		•				•					308756
•		232200	•				•		•				•	•	•		Silver Plus HD RAC	308756
	•	232211	•				•		•				•	•	•		Silver Plus HD RAC	308756
•		232269	•		•	200	•	•	•	•	•		•	•	•		Silver Plus HD RAC	308759
	•	232357	•		•	200	•	•	•	•	•		•	•	•		Silver Plus HD RAC	308759
•		232267	•		•	240	•	•	•	•	•		•	•	•		Silver Plus HD RAC	308759
	•	232355	•		•	240	•	•	•	•	•		•	•	•		Silver Plus HD RAC	308759
•		232268	•		•	480	•	•	•	•	•		•	•	•		Silver Plus HD RAC	308759
	•	232356	•		•	480	•	•	•	•	•		•	•	•		Silver Plus HD RAC	308759
•		231063		•	•		•	•					•		•		Silver Plus Fine Finish	306706
	•	231922			•		•		•				•					308635
	•	231932			•		•		•				•					308635
•		231921			•		•		•				•	•	•		Silver Plus HD RAC	308635
	•	231931			•		•		•				•	•	•		Silver Plus HD RAC	308635
•		231923			•		•		•				•	•	50 ft.		Silver Plus HD RAC	305635
	•	231933			•		•		•				•	•	50 ft.		Silver Plus HD RAC	308635
•		231973			•	•	120	•	•	•	•		•	•	•		Silver Plus HD RAC	308692
	•	232028			•	•	120	•	•	•	•		•	•	•		Silver Plus HD RAC	308692
•		231974			•	•	240	•	•	•	•		•	•	•		Silver Plus HD RAC	308692
	•	232029			•	•	240	•	•	•	•		•	•	•		Silver Plus HD RAC	308692

Note: President 30:1 packages include a GHD617 tip with an additional tip of choice.

President 30:1 55 gallon (200 l) drum package includes a 163xxx tip of choice.

### PRESIDENT 46:1 AIRLESS SPRAY PACKAGES

4600 psi (317 bar, 31.7 MPa)

Carbon Steel	Stainless Steel	Part Number	Wall-Mount	55 Gallon (200 l) Drum Mount Elevator	Heavy-Duty Cart-Mount Heated Package	Heater Voltage	Fluid Filter	Agitator	Siphon Tube	Back Pressure Regulator	Circulation Kit	Circulation Manifold	Bare Package - no hose or gun	Fluid Swivel at Gun Inlet	Whip Hose 2 ft. (0.6 m)	Fluid Hose 25 ft. (7.6 m)	Applicator	Instruction Manual
•		232264	•				•		•				•					308756
•		232263	•				•		•				•	•	•		Silver Plus HD RAC	308756
•		232025			•		•		•				•	•	•		Silver Plus HD RAC	308635

Note: President 46:1 packages include a GHD617 tip with an additional tip of choice.

# Monark 23:1, President 30:1 and 46:1 Airless Spray Packages

## Accessories

### Whip Hoses

Maximum working pressure: 3000 psi (207 bar, 20.7 MPa).

1/4 npt(m) x 1/4 npsm(f). CS wetted fittings.

**236134** 1/8 in. x 3 ft. (3 mm x 0.9 m)

**236135** 1/8 in. x 6 ft. (3 mm x 1.8 m)

Maximum working pressure: 4100 psi (280 bar, 20.7 MPa). 1/4 npsm(fbe). SST wetted fittings.

**239069** 3/16 in. x 23.6 in. (4.7 mm x 0.6 m)

**239108** 1/4 in. x 23.6 in. (6.3 mm x 0.6 m)

Maximum working pressure: 4100 psi (280 bar, 28 MPa). 1/4 npsm(fbe). CS wetted fittings.

**238708** 3/16 in. x 23.6 in. (4.7 mm x 0.6 m)

**238709** 3/16 in. x 39.4 in. (4.7 mm x 1 m)

**238822** 1/4 in. x 23.6 in. (6.3 mm x 0.6 m)

**239082** 3/16 in. x 39.4 in. (4.7 mm x 1 m)

### Fluid Hoses

Maximum working pressure: 4100 psi (280 bar, 28 MPa). 1/4 npsm(fbe). CS wetted fittings.

**238711** 3/16 in. x 16.4 ft. (4.7 mm x 5 m)

**238712** 3/16 in. x 24.6 ft. (4.7 mm x 7.5 m)

**238713** 3/16 in. x 50 ft. (4.7 mm x 15 m)

**238826** 1/4 in. x 24.6 ft. (6.3 mm x 7.5 m)

**238827** 1/4 in. x 50 ft. (6.3 mm x 15 m)

Maximum working pressure: 4100 psi (280 bar, 28 MPa). 1/4 npsm(fbe). SST wetted fittings.

**239107** 1/4 in. x 24.6 ft. (6.3 mm x 7.5 m)

**239110** 1/4 in. x 32.8 ft. (6.3 mm x 10 m)

**239111** 1/4 in. x 50 ft. (6.3 mm x 15 m)

Maximum working pressure: 5000 psi (345 bar, 34 MPa). CS wetted fittings.

**238385** 1/4 in. x 24.6 ft. (6.3 mm x 7.5 m)

**238396** 3/8 in. x 50 ft. (9.5 mm x 15 m)

Maximum working pressure: 7400 psi (503 bar, 50 MPa)

**237072** 3/8 in. x 50 ft. (9.5 mm x 15 m)

**237070** 1/4 in. x 6 ft. (6.3 mm x 1.8 m)

### 189018 Fluid Swivel

Maximum working pressure: 5800 psi (400 bar, 40 MPa). To ease movement of the gun and fluid hose. 1/4-18 npsm. Does not include filter chamber and tip filter.

### 239394 Fluid Swivel/Filter

Maximum working pressure: 5800 psi (400 bar, 40 MPa). To ease movement of the gun and fluid hose. 1/4-18 npsm.

### Fluid Heaters

Maximum working pressure: 4000 psi (272 bar, 27.2 MPa). SST.

**220522** 120V

**220523** 240V

**220524** 480V

**237312** 200V

### 208259 Siphon Kit, Carbon Steel

Use to siphon fluid from a 55 gallon (200 l) drum. Includes nylon suction hose 214961, 3/4" ID, 6 ft. (1.8 m), 3/4 npt(f) swivel outlet fitting, bung adapter.

### 208920 Siphon Kit, Aluminum

Use to siphon fluid from a 5 gallon (18.9 l) pail. Includes nylon suction hose 170706, 1" ID, 4 ft. (1.2 m) long, 3/4 npt(f) swivel outlet fitting, inlet strainer.

### 207484 Siphon Kit, Aluminum

Use to siphon fluid from a 5 gallon (18.9 l) pail. Includes nylon suction hose 214960, 3/4" ID, 3.5 ft. (1.1 m) long, 3/4 npt(f) swivel outlet fitting.

### 236054 Suction Kit, Carbon Steel

Use to siphon material out of a 55 gallon (200 l) closed-end drum. Includes siphon tube, bung adapter, 6 ft. (1.8 m) nitrile hose and 1-1/2 npt(m) outlet fitting.