

8900 Proportioner

Plural Component Fixed & Variable

8900 Information and Specifications

How the 8900 Works

The 8900 proportioner uses fluid inlet pressure to continuously reciprocate two connected cylinders. This fluid pressure is usually provided by two pumps which supply consistent pressure to the proportioner cylinders. As the major volume cylinder (base) and minor volume cylinder (catalyst) reciprocate, they positively displace the two material components on ratio to the outlet ports. Specially-sized hoses connect the proportioner to a choice of mixers to ensure ratio accuracy. Static mixers are incorporated into the system to deliver a homogeneous mix of base and catalyst.

System Components:

A complete system is assembled by selecting four equipment modules.

Each system includes the following components:

- Fixed or variable ratio power valved passive proportioner module
- Pump feed module for base material
- Pump feed module for catalyst material
- Mix/dispense module

Choose one of each component, plus any accessories to complete a modular system.

Double Action Proportioner Operation

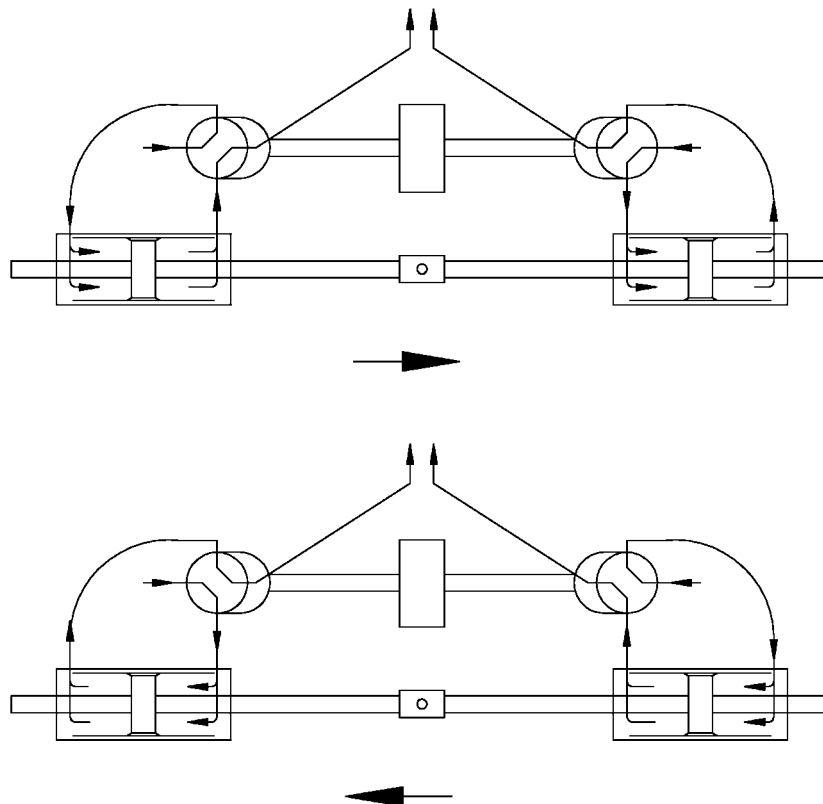

8900 Proportioner

Plural Component Fixed & Variable

Proportioner Module Selection

The material ratio of the application is used to determine the ideal proportioner for the complete system. Depending on the application, you will need either a Fixed Ratio Proportioner or a Variable Ratio Proportioner.

Fixed Ratio Proportioner Systems

Fixed Ratio Proportioner systems are available for mix by the following volume ratios: 1:1, 2:1, 2.5:1, 4:1, 5:1, and 10:1.

Variable Ratio Proportioner Systems

All other volume ratios require a Variable Ratio Proportioner. Select a Variable Ratio Proportioner with the material ratio closest to the lower limit out of the four available models (Example: if a 3.62 ratio is required, choose 2:1 to 8:1 system). Following this guideline will ensure a longer stroke on the slave cylinder.

Cylinders

All 8900 proportioners use two of four available cylinders:

Cylinder Size	Effective Area In. ² (cm ²)	Output Per Full 5 in. Stroke
# 1000	6.627	.143 gal. (543 cc)
# 500	3.313	.072 gal. (271 cc)
# 250	1.657	.036 gal. (136 cc)
# 100	0.663	.014 gal. (54.3 cc)

Technical Specifications

Maximum working fluid pressure 2500 psi (172 bar; 17.2 MPa)

Approximate weight

Fixed Ratio Proportioner 350 lb. (158.75 kg)

Variable Ratio Proportioner 450 lb. (204.11 kg)

Dimensions

Fixed Ratio Proportioner 15.2 in. H x 43 in. W x 11.6 in. D
(386 mm x 1092 mm x 295 mm)

Variable Ratio Proportioner 16.5 in. H x 38 in. W x 19.5 in. D
(419 mm x 965 mm x 495 mm)

Fluid inlet connections 3/4 npt(f)

Fluid outlet connections 3/4 npt(f)

Wetted parts 303 and 17-4 PH SST, Teflon®, aluminum, plated carbon steel, Hytrel®

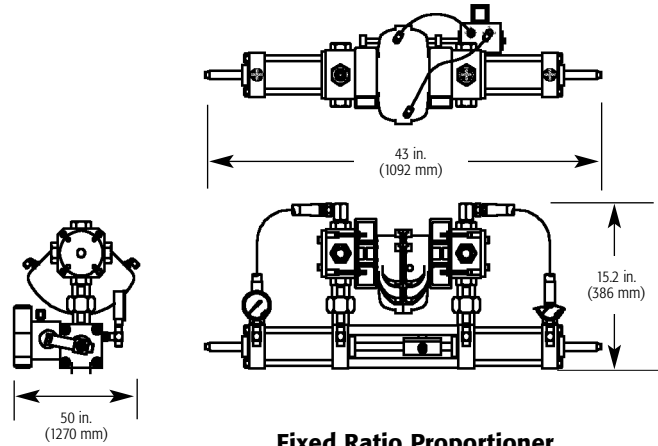

Fixed Ratio Proportioner

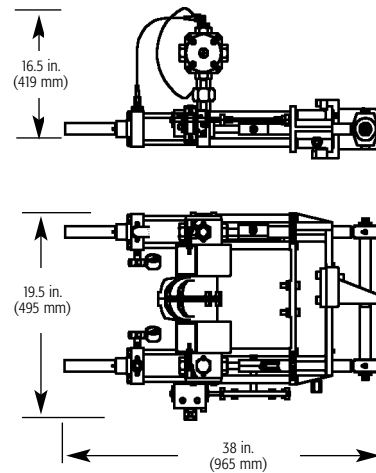

Variable Ratio Proportioner

8900 Proportioner

Plural Component Fixed & Variable

Feed Module for Base & Catalyst Selection

The ideal pump feed modules for the Base and the Catalyst materials are determined by two factors:

- The size of the material containers
- The working pressure needed to pump the materials

Use the following chart to select the most appropriate pump for the application:

Container Size	Material Characteristics	Module Choice
1 gal. (3.8 liter)	Medium viscosity (self-leveling, 50 K - 200 K)	H
5 gal. (18.9 liter)	Medium viscosity (pourable grade, 50 K - 200 K)	J or K (installation preference)
	High viscosity, non-abrasive (200 k - 2 m)	A or C
	High viscosity, abrasive (200 k - 2 m)	B
55 gal. (208 liter)	Medium Viscosity (pourable grade, 50 K - 200 K)	G
	High Viscosity (200 k - 2 m)	D, E, or F *

A) President 20:1 on 5G Ram (965571)	D) President 20:1 on 55 G Drum (570144)
B) Senator 34:1 on 5G Ram (965597)	E) Senator 34:1 on 55G Ram (965572)
C) Monark 23:1 on 5G Ram (570142)	F) Bulldog 31:1 on 55G Ram (570141)

* Choose pump based on maximum flow and production requirements. Consult your authorized Graco distributor for guidance in selecting the appropriate pump.

Feed Modules for Base and Catalyst Supply

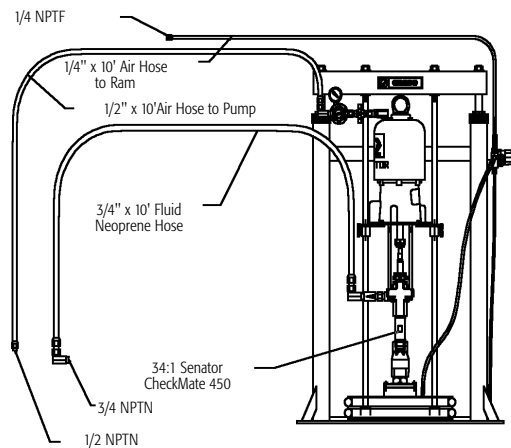
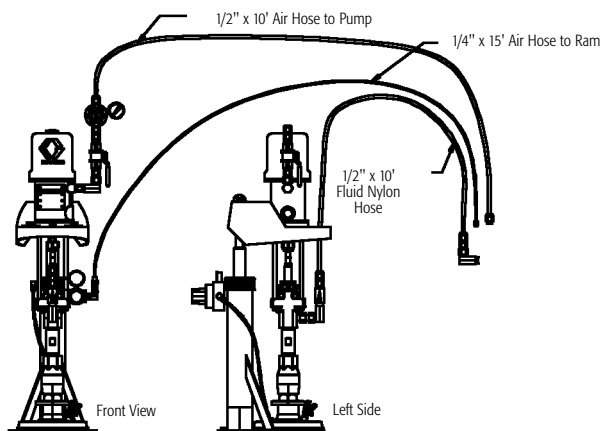

8900 Proportioner

Plural Component Fixed & Variable

Feed Module for Base & Catalyst Selection

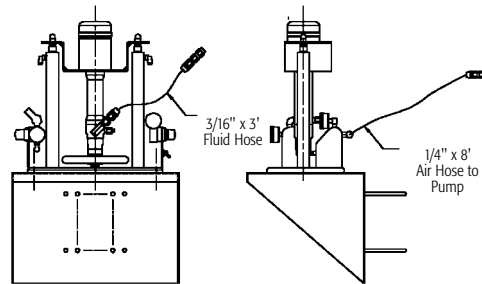
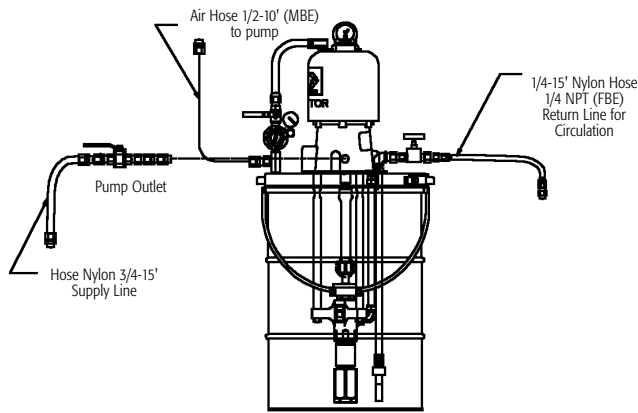

G) Senator 20:1 on 55 gal. (208 liter) Drum Cover & Elevator (570309)

H) Dynamite 9:1 1gal. (3.8 liter) Can Ram with U-Bolts to mount to Ram Tube or Stanchion (570249)

4

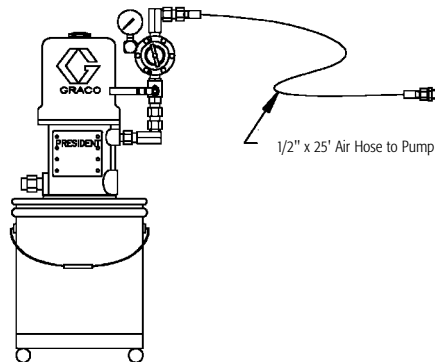
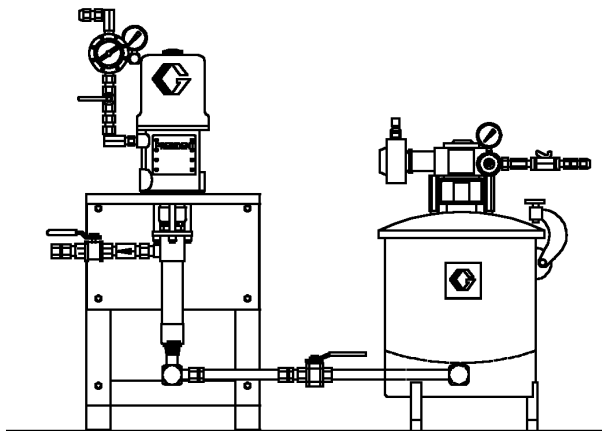

J) 10 gal. (38 liter) Press Tank with 15:1 Booster (570037)

K) President 10:1 5 gal. (18.9 liter) Pail Cover (570264)

8900 Proportioner

Plural Component Fixed & Variable

Mix Kit Selection

Choose a Cartridge Fill Module (1 - 3), 2K UL Gun Module (4 - 7) or High Volume Mix (8 - 9) based on cell layout and application requirements.

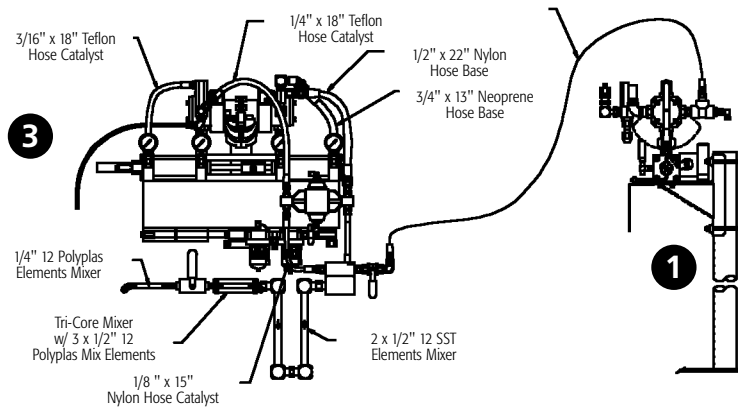

1) Cartridge Fill Medium Viscosity Wide Ratio (570248)

3) Brush Grade Cartridge Fill Wide Ratio (570358)

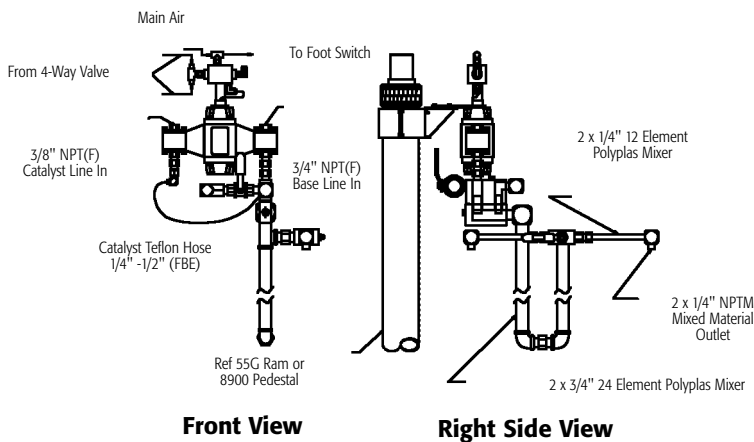

2) Cartridge Fill High Viscosity Wide Ratio (570318)

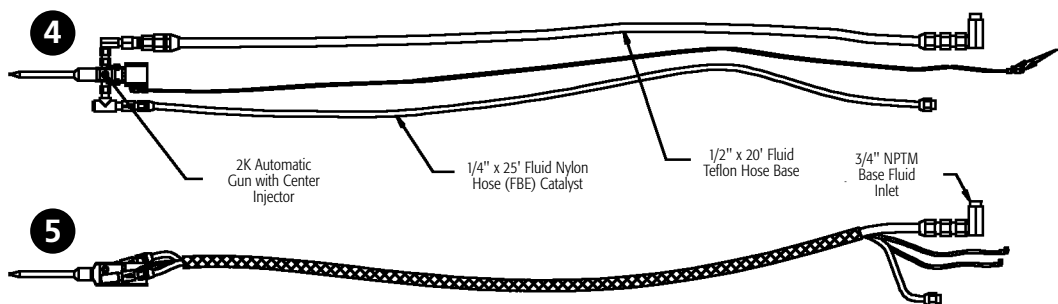

Air Signals to Valve
 "Air to Open"
 "Air to Close"
 1/8 NPT(M) Fittings on 5/32" OD Tubing

4) 2K Ultra-Lite 20 ft (6 m) Automatic Wide Ratio (570144)

5) 2K Ultra-Lite 20 ft (6 m) Automatic Close Ratio (570362)



8900 Proportioner

Plural Component Fixed & Variable

Mix Kit Selection

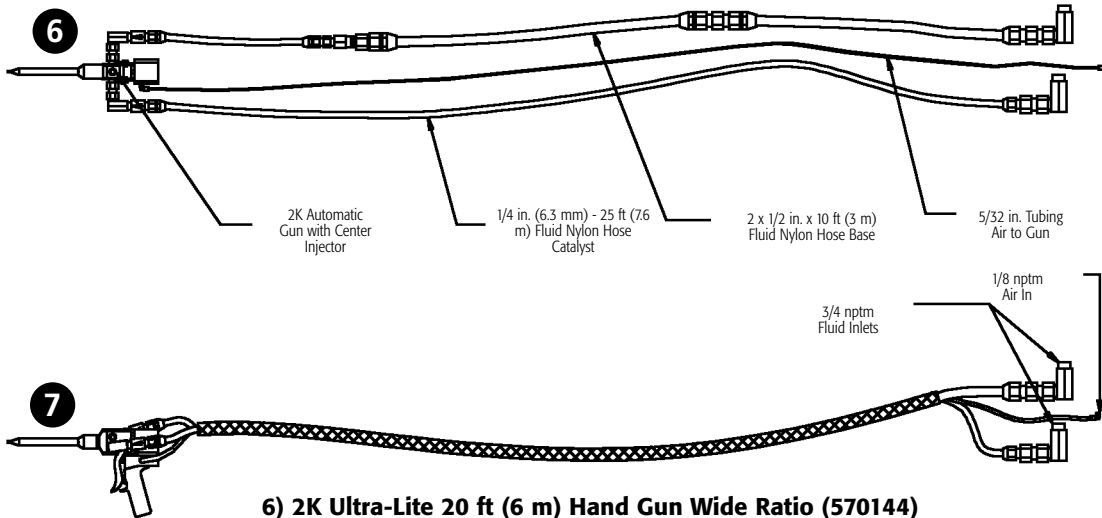

6) 2K Ultra-Lite 20 ft (6 m) Hand Gun Wide Ratio (570144)
7) 2K Ultra-Lite 20 ft (6 m) Hand Gun Close Ratio (570091)

4

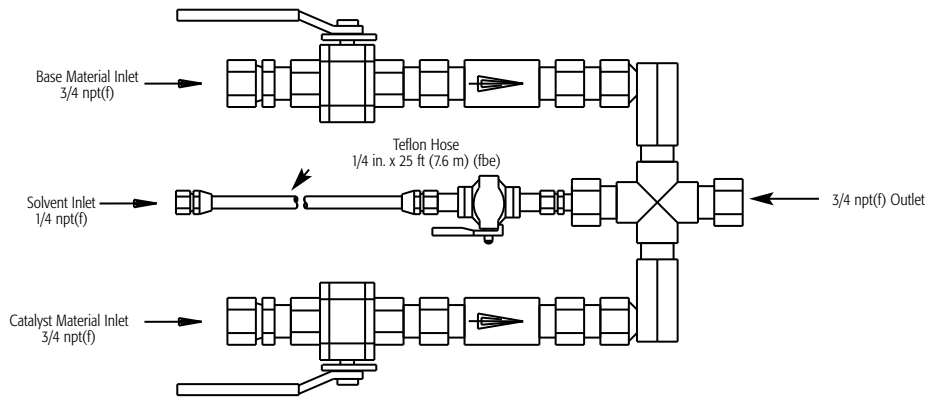

8) High Vol. Static Mix Manifold (570391)

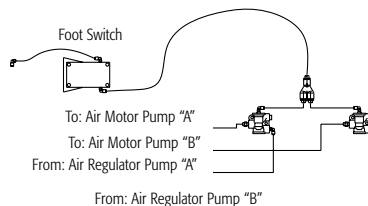
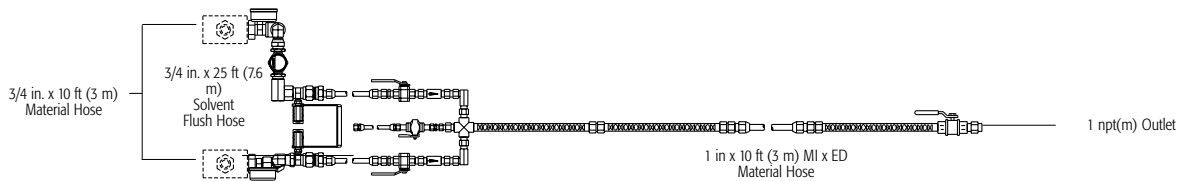

9) High Vol. Static Mix Kit with Pump Pilots (570263)

8900 Proportioner

Plural Component Fixed & Variable

Mix Kit Selection Summary

Technical Data

Code	Dispense Valve	Mixer	Hoses	Wetted Parts
1	Dual Outlet through Diverter Valve	2x 1/2 in. el SST + Tri-Core Mixer (3x 1/2 in. 12 polyplas mix elements) + 2x 1/4 in. 12 polyplas elements	18 in. x 15 in. nylon (catalyst)	Polyplas, Teflon, 303 SST plated CS, aluminum
2	Dual Outlet through Diverter Valve	2x 3/4 in. 24 el + 2x 1/4 in. 12 el Polyplas elements mixer	1/4 in. x 12 in. Teflon (catalyst)	Polyplas, Teflon, 303 SST plated CS, aluminum
3	1K Ultra-Lite Automatic Gun	Tri-Core Mixer 3x 1/2 in. 12 polyplas mix elements + 2x 1/2 in. SST elements + 2x 1/4 in. 32 polyplas elements mixers	1/4 in. x 12 in. Teflon (catalyst)	Polyplas, Teflon, 303 SST plated CS, aluminum, 17-4 ph SST, C2 carbide, hard chrome, ethylene propylene, Parker Polymite
4	2K Ultra-Lite Automatic Gun	3/8 in. ID 24 plastic elements disposable mixer	12 in. x 20 in. Teflon (base), 14 in. x 25 ft nylon (catalyst)	Teflon, 303 SST, 17-4 ph SST, C2 carbide, hard chrome, ethylene propylene, Parker Polymite
5	2K Ultra-Lite Automatic Gun	3/8 in. ID 24 plastic elements disposable mixer	12 in. x 20 in. Teflon (base), 14 in. x 25 ft nylon (catalyst)	See Code 4
6	2K Ultra-Lite Hand Gun	3/8 in. ID 30 plastic elements disposable mixer	2x 12 in. x 10 ft nylon (base), 14 in. x 25 ft. nylon (catalyst)	See Code 4
7	2K Ultra-Lite Hand Gun	See Code 6	See Code 6	See Code 4
8	None	None	1/4 in. 25 ft Teflon (solvent)	Plated carbon steel
9	1 in. Ball Valve	3 x 1 in. 12 elements pipe mixer, 1800 psi maximum working pressure	3/4 10 ft. neoprene 1 in. 10 ft (mixed material) 1/4 in. 25 ft Teflon (solvent)	330 SST, plated carbon steel, Neoprene, Teflon

Mounting Type Selection

Choose stanchion (S) or none (N) if mounting the 8900 Proportioner on a 55 gal (200 liter) feed module.

8900 Proportioner

Plural Component Fixed & Variable

Accessories

- 626698** Structural steel tubes (4 in. x 6 in.) for mounting two 55 gal. (200 liter) ram feed modules side by side. Could be used as stationary or portable unit (with added casters). Order two tubes (626698).
- 570264** President 10:1 mounted on a 5 gal. (19 liter) pail. Used for solvent flush of mix kit assembly.
- 570310** **Low-level shut-off kit**
For proportioner drum ram when used with 2K Ultra-Lite disposable mixer gun kits. Mounts to ram air cylinders and works with the motor air pilot valve.

Repair Kits for Major and Minor Metering Cylinders

Size	Meter Repair Kit	Cup (Order 2)	Ratio Cylinder	Ratio Kit*
#1000	C24166	C05032	C23136	C23041
#500	C24166	C23350	C23200	C23087
#250	C24166	C23318	C23171	C23067
#100	C24166	C22282	C23137	C23042

* Ratio kit includes: ratio cylinder, cup (qty. 2), spacer and back-up (qty. 2)

Repair Kits for All Proportioners

For Part Number	Repair Kit	Replacement Parts
Actuator C24046		C24047
4-Way Valve, 3/16 in. C24039	C07067	C07069 Trunion 3/16 in. inside port
4-Way Valve, 5/8 in. C24029	C07067	C07068 Trunion 5/8 in. inside port

Configured Product Order Form—8900 Proportioner

Fax completed form and Purchase Order to Graco Customer Service:

Fax (800) 334-6955 North America

(612) 623-6884 International

For Graco Use

S/R # _____

System # _____

Account Number: _____ PO Number: _____ Date: _____

Ship To:
Attn:

Bill To:
Attn:

MODEL CODE AND PRICING INFORMATION—Refer to the latest price book for the most current pricing and fill in appropriate blanks.

Typical Model Number: 8900-C- 1 - D - C - 2 - N				Code C	Pump Feed Module Selection for Catalyst	Add
Model	Product Description	List Price		A	20:1 President on 5 Gal. Ram	965571 \$
8900-B	Power Valved Passive Proportioner			B	34:1 Senator on 5 Gal. Ram	965597
Code A	Proportioner Selection ("A" Cyl./"B" Cyl.)	Add		C	23:1 Monark on 5 Gal. Ram	570142
1	1:1 Fixed (1000/1000)	570371 \$		D	20:1 President on 55 Gal. Ram	570114
2	2:1 Fixed (1000/500)	570372		E	34:1 Senator on 55 Gal. Ram	965572
3	2:5:1 Fixed (250/100)	570373		F	31:1 Bulldog on 55 Gal. Ram	570141
4	4:1 Fixed (1000/250)	570374		G	20:1 Senator on 55 Gal. Drum	570309
5	5:1 Fixed (500/100)	570375		H	9:1 DynaMite 1 Gal. Can Ram	570249
6	10:1 Fixed (1000/100)	570376		J	10 Gal. Press Tank w/ 15:1 Booster	570037
A	1:1 to 4:1 Variable (500/500)	570377		K	10:1 President 5 Gal. Pail Cover	570264
B	2:1 to 8:1 Variable (500/250)	570378		N	None	N/C
D	5:1 to 20:1 Variable (500/100)	570380		Code D	Mix Kit Selection	Add
Code B	Pump Feed Module Selection for Base	Add		1	Cart Fill Medium Vis Wide Ratio	570248 \$
A	20:1 President on 5 Gal. Ram	965571 \$		2	Cart Fill High Vis Wide Ratio	570318
B	34:1 Senator on 5 Gal. Ram	965597		3	Brush Grade Cart Fill Wide Ratio	570358
C	23:1 Monark on 5 Gal. Ram	570142		4	2K Ultra-Lite 20' Auto Wide Ratio	570144
D	20:1 President on 55 Gal. Ram	570114		5	2K Ultra-Lite 20' Auto Close Ratio	570362
E	34:1 Senator on 55 Gal. Ram	965572		6	2K Ultra-Lite 20' Hand Gun Wide Ratio	570363
F	31:1 Bulldog on 55 Gal. Ram	570141		7	2K Ultra-Lite 20' Hand Gun Close Ratio	570091
G	20:1 Senator on 55 Gal. Drum	570309		8	High Vol. Static Mix Manifold	570391
H	9:1 Dynamite 1 Gal. Can Ram	570249		9	High Vol. Static Mix Kit w/ Pump Pilots	570263
J	10 Gal. Press Tank w/ 15:1 Booster	570037		N	None	N/C
K	10:1 President 5 Gal. Pail Cover	570264		Code E	Mounting Type Selection	Add
N	None	N/C		S	Stanchion	570071 \$
				N	None (mount on 3" 55 Gal. Ram)	N/C
					List Price (each)	\$

ORDER INFORMATION—Not intended for quoting purposes. Purchase Order must accompany order. No verbal orders accepted.

Model Number 8900-C- - - - -

Code: A B C D E

Note: Orders Cancelled prior to shipment are subject to a 25% restocking fee. Configured products are not returnable.

Order Quantity _____ X List Price (each) _____ = Total Price _____

Distributor Requested Ship Date: _____
(Please contact Graco Customer Service for Delivery Information)

Print Name: _____ Signature: _____ Date: _____

Note: For the full 8900 Proportioner configured order form and instructions, order Graco form 684041.

